

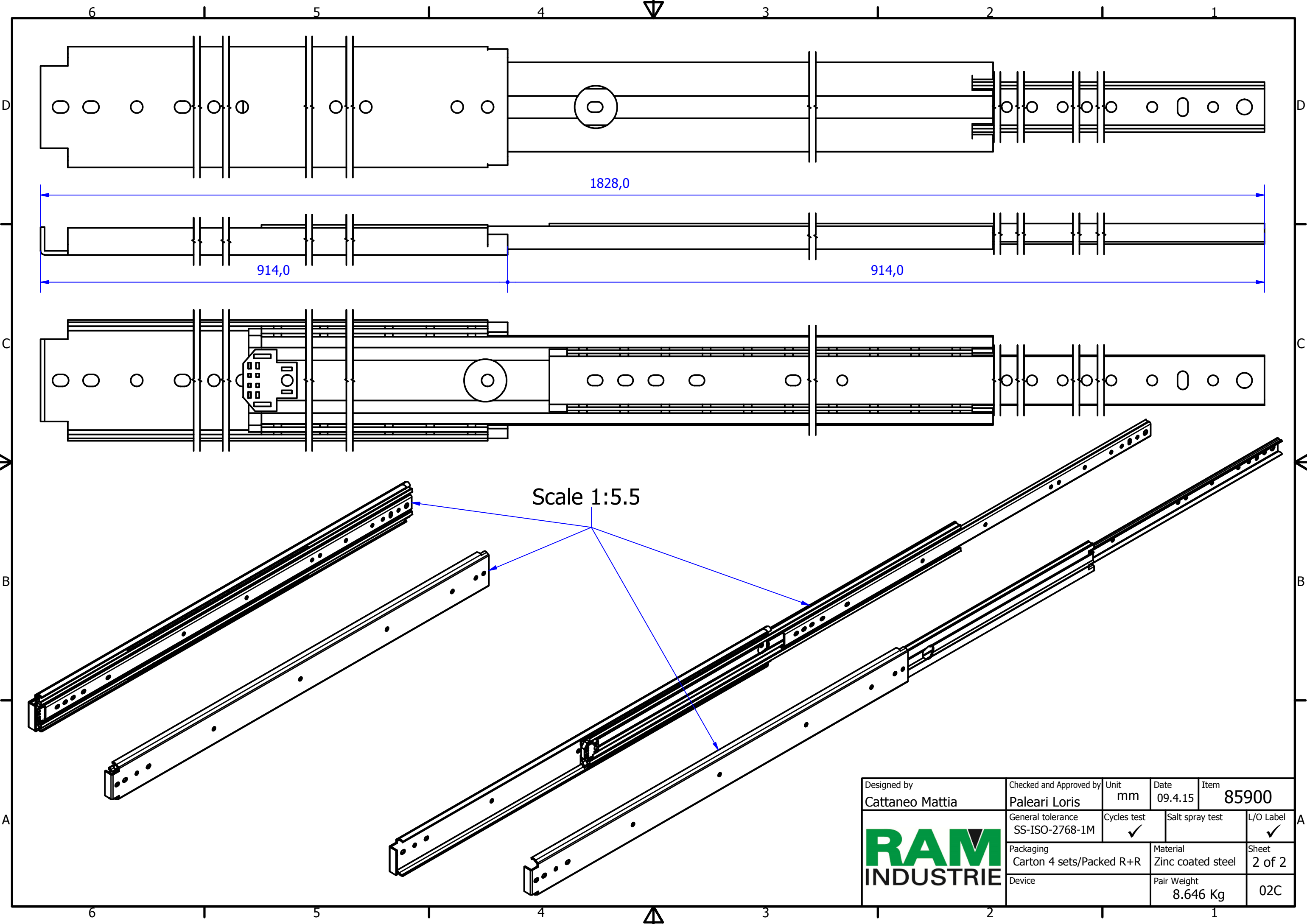

Designed by Cattaneo Mattia	Checked and Approved by Paleari Loris	Unit mm	Date 09.4.15	Item 85900
		General tolerance SS-ISO-2768-1M	Cycles test ✓	Salt spray test ✓
		Packaging Carton 4 sets/Packed R+R	Material Zinc coated steel	Sheet 1 of 2
Device			Pair Weight 8.646 Kg	02C



Scale 1:5.5

Designed by Cattaneo Mattia	Checked and Approved by Paleari Loris	Unit mm	Date 09.4.15	Item 85900
		General tolerance SS-ISO-2768-1M	Cycles test ✓	Salt spray test
		Packaging Carton 4 sets/Packed R+R	Material Zinc coated steel	L/O Label ✓
Device			Pair Weight 8.646 Kg	Sheet 2 of 2 02C