

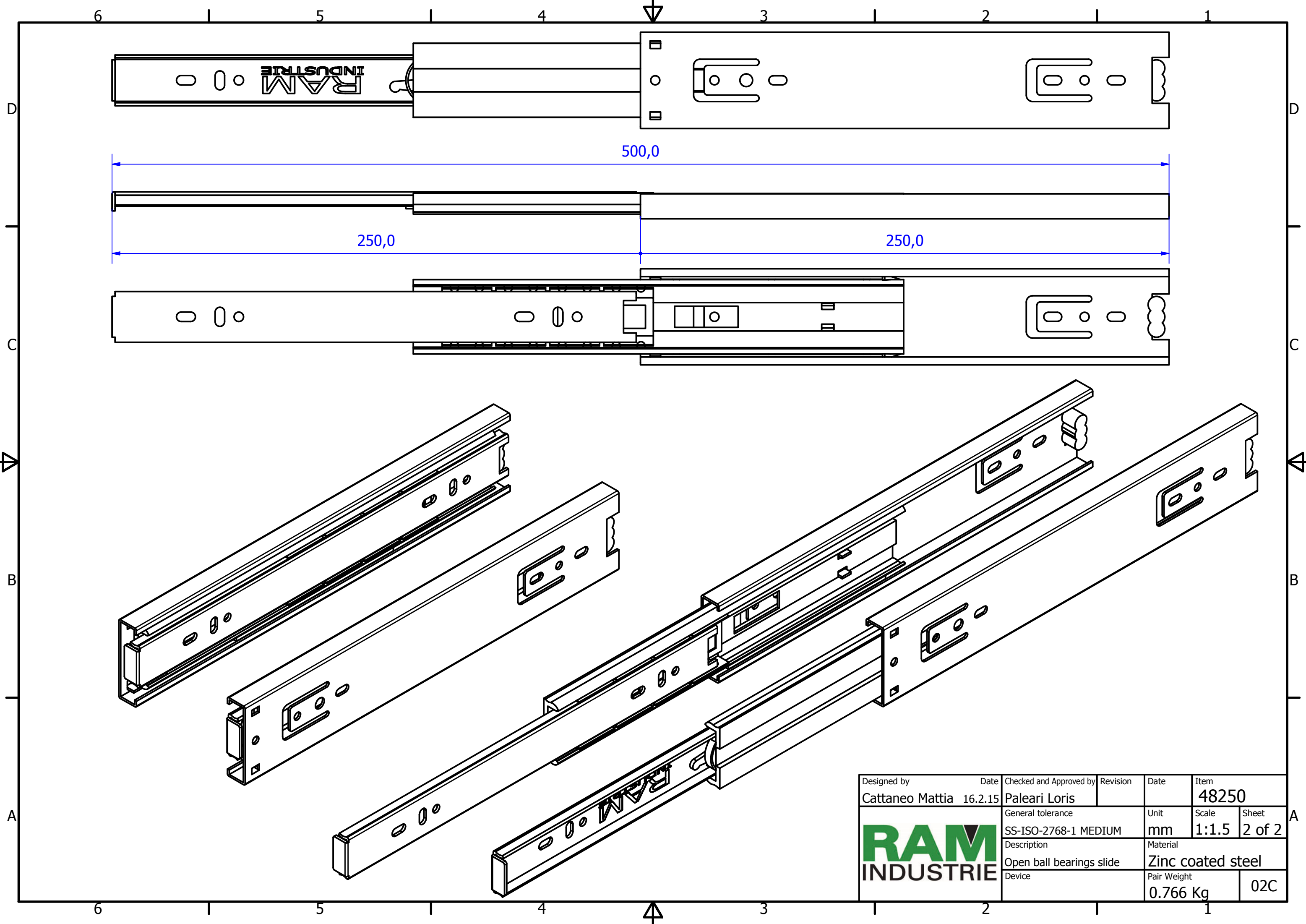

Designed by Cattaneo Mattia	Date 16.2.15	Checked and Approved by Paleari Loris	Revision	Date	Item 48250
		General tolerance SS-ISO-2768-1 MEDIUM		Unit mm	Scale 1:1
		Description Closed ball bearings slide		Material Zinc coated steel	
Device		Pair Weight 0.766 Kg		Sheet 1 of 2 02C	



Designed by Cattaneo Mattia	Date 16.2.15	Checked and Approved by Paleari Loris	Revision	Date	Item 48250
			General tolerance SS-ISO-2768-1 MEDIUM	Unit mm	Scale 1:1.5
			Description Open ball bearings slide	Material Zinc coated steel	
Device				Pair Weight 0.766 Kg	02C

D  
C  
B  
A

D  
C  
B  
A

6 1 5 1 4 3 1 2 1 1

6 1 5 1 4 3 1 2 1 1