

1000,0

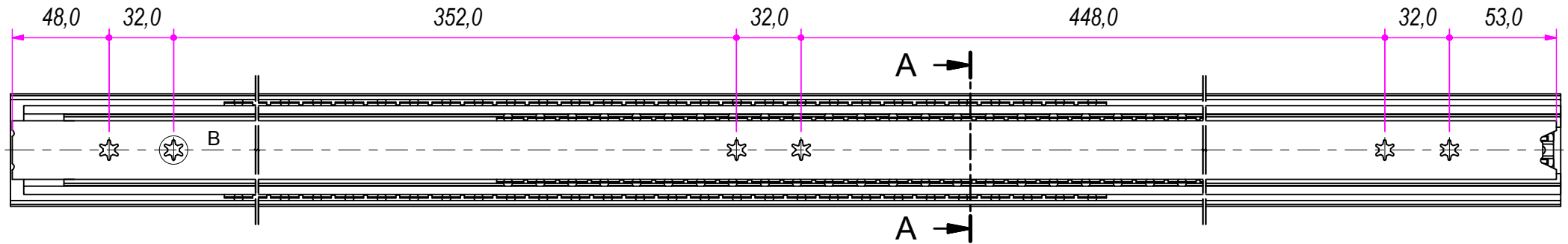

SEZ. A-A

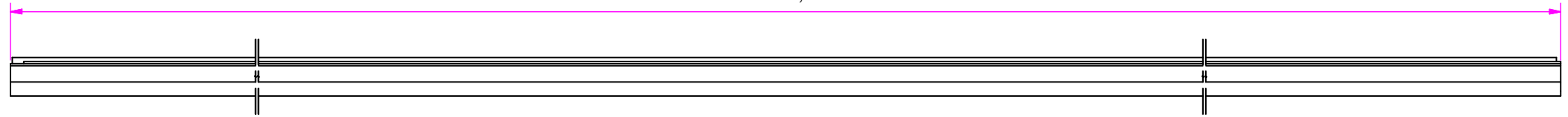
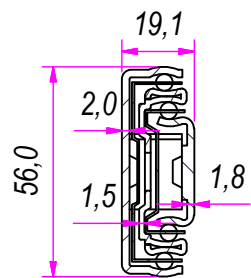

B (1:1)

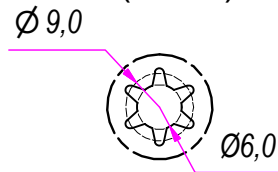

Guide per cassetti; guide telescopiche	Coulisses à billes; coulisse télescopique	
Drawer slide; telescopic ball bearing slide	Guías para cajones; guía teleópica	REV
Kugelführung; Teleskopschienen		1a

REVISION HISTORY	
DESCRIPTION	DATE
	17/04/2018

DESIGNED BY F.Dino	CHECKED AND APPROVED BY L. Paleari	GENERAL TOLLERANCE SS-ISO-2768-1M	DATE 17/04/2018	CODE 831000
PACKAGING Carton 4 sets/Packed R+R			UNIT mm	SHEET 1 of 2
DESCRIPTION RAM INDUSTRIE			MATERIAL Cold rolled steel	
DEVICE			PAIR WEIGHT 5,974 Kg	01T
Property of RAM Industrie. Without its written authorization the present drawing shall neither be used for construction anyway, communicated to third parties, nor reproduced.				

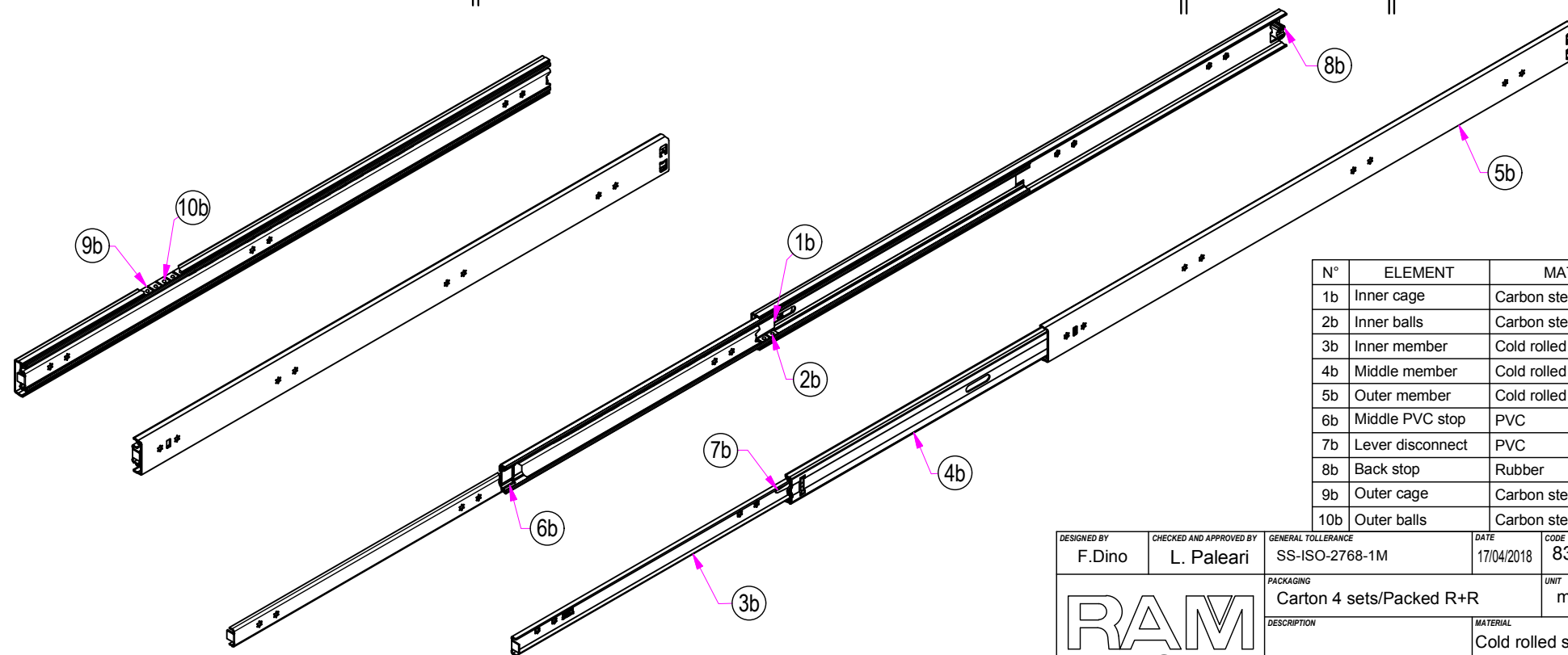
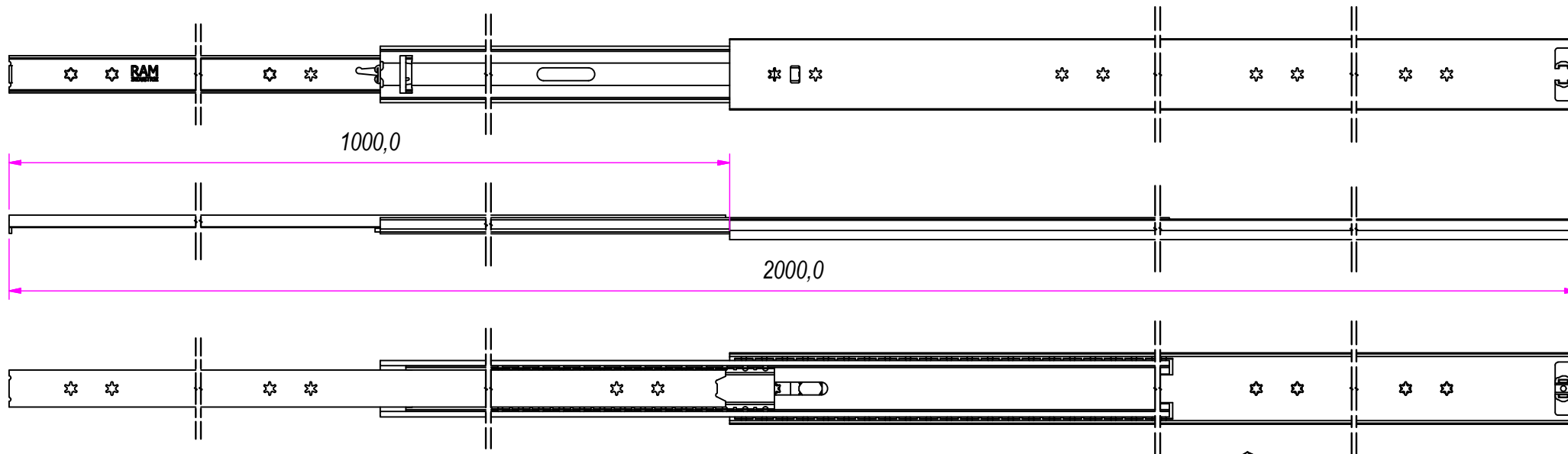

N°	ELEMENT	MATERIAL
1b	Inner cage	Carbon steel
2b	Inner balls	Carbon steel
3b	Inner member	Cold rolled steel
4b	Middle member	Cold rolled steel
5b	Outer member	Cold rolled steel
6b	Middle PVC stop	PVC
7b	Lever disconnect	PVC
8b	Back stop	Rubber
9b	Outer cage	Carbon steel
10b	Outer balls	Carbon steel

DESIGNED BY F. Dino	CHECKED AND APPROVED BY L. Paleari	GENERAL TOLLERANCE SS-ISO-2768-1M	DATE 17/04/2018	CODE 831000
PACKAGING Carton 4 sets/Packed R+R		UNIT mm	SHEET 2 of 2	
DESCRIPTION RAM INDUSTRIE			MATERIAL Cold rolled steel	
DEVICE			PAIR WEIGHT 5,974 Kg	01T

GUIDE per cassetti; guide telescopiche		Coulisses à billes; coulisse télescopique		REVISION HISTORY	
Drawer slide; telescopic ball bearing slide		Guías para cajones; guía teleópica		REV	DESCRIPTION
Kugelführung; Teleskopschienen				DATE	
				1a	17/04/2018

Property of RAM Industrie.
Without its written authorization the present drawing shall neither be used for construction anyway, communicated to third parties, nor reproduced.