

Sez.A-A scala 1:15

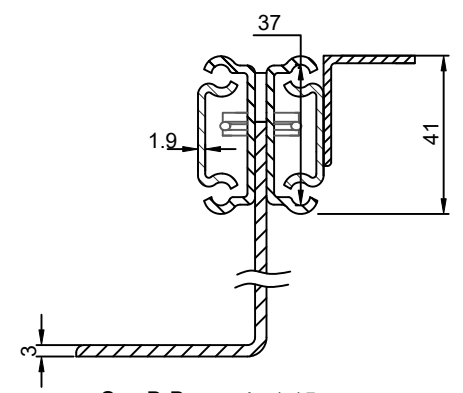

Sez.B-B scala 1:15

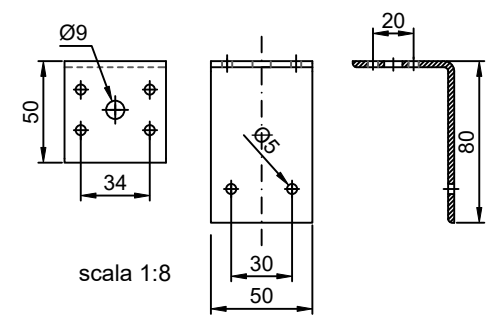

scala 1:8

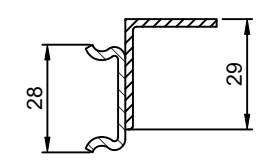
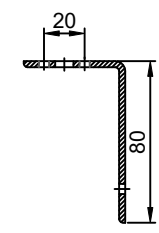

Sez.C-C scala 1:15

Designed by	Date	Checked and Approved by	Revision	Date	Item
brancato cristian	13.07.23	Paleari Loris			F98
General tolerance		Unit	Scale	Sheet	
SS-ISO-2768-1 MEDIUM		mm	1:30	1 of 2	
Description		Material			
Closed ball bearings slide		steel			
Device		Pair Weight			
		14.3 Kg			
<small>La ditta si riserva di apportare eventuali modifiche senza preavviso.</small>					